

Safety sensors

EX-BNS 180-...-3G/D

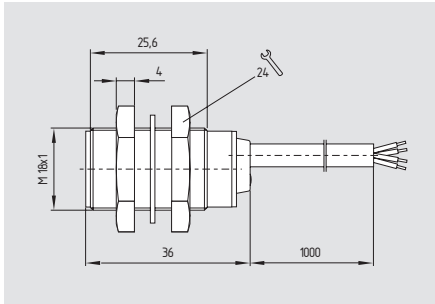

- Ex certified
- Thermoplastic enclosure
- long life, no mechanical wear
- Protection class IP 67
- Intensive to transverse misalignment
- Intensive to soiling
- Particularly large switching distance
- Suitable for food processing industry

Technical data

Equipment category: II 3GD
 Ex protection: Ex nC IIC T6 X
 Ex tD A22 IP67 T80°C X
 Standards: EN 60947-5-3, EN 61241-0,
 EN 61241-1, EN 60079-0,
 EN 60079-15, BG-GS-ET-14

Design: cylindrical
 Enclosure: glass-fibre reinforced thermoplastic
 tightening torque A/F 24 max. 500 Ncm

Max. impact energy: 1 J
 Protection class: IP 67 to EN 60529
 Connection: Boflex cable
 Cable section: 6 x 0.25 mm²
 Operating principle: magnetic
 Actuating magnet: BP 6, BP 8, BP 10,
 BP 15 SS, not coded

S_{ao}: 8 mm (BP 6 / BP 8)
 18 mm (BP 10 / BP 15 SS)
 S_{ar}: 20 mm (BP 6 / BP 8)
 28 mm (BP 10 / BP 15 SS)

Switching voltage max. without LED: 120 VAC/DC
 Switching current: max. 250 mA
 Switching capacity: max. 5 W
 Ambient temperature: -25 °C ... +70 °C
 Storage and transport temperature: -25 °C ... +70 °C
 Max. switching frequency: 5 Hz
 Resistance to shock: 30 g / 11 ms
 Resistance to vibration: 10 ... 55Hz,
 Amplitude 1 mm

Classification:

Standards: EN ISO 13849-1
 B_{10d} NC/NO contact: 25.000.000
 at 20% contact load
 Service life: 20 years

$$MTTF_d = \frac{B_{10d}}{0,1 \times n_{op}} \quad n_{op} = \frac{d_{op} \times h_{op} \times 3600 \text{ s/h}}{t_{cycle}}$$

Contact variants

1 NO / 2 NC contacts

GY 13 → 14 PK
 GN 21 → 22 YE
 WH 31 → 32 BN

Approvals



Ordering details

EX-BNS 180-12z-2187-2-3G/D

Note

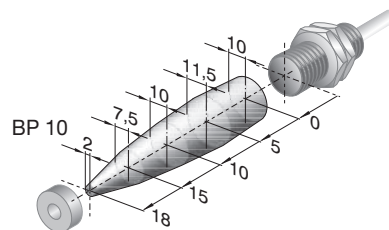

Enabling zone

The actuators for the magnetic safety sensors must be ordered separately.

Note

Contact symbols shown for the closed condition of the guard device.

The safety sensor is to be installed in such a way that operation with a magnet is not possible (covered installation in accordance with EN 1088).

Safety sensors

System components

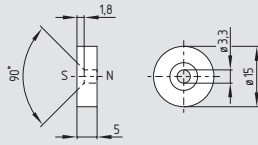

BP 6

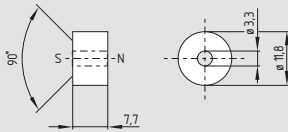

BP 8

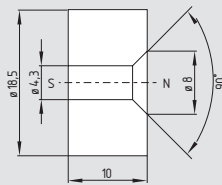

BP 10

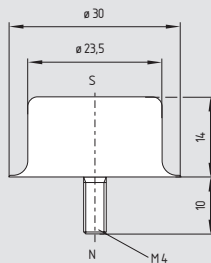

BP 15 SS

Ordering details

Actuating magnets:

- unenclosed **BP 6**
- unenclosed **BP 8**
- unenclosed **BP 10**
- stainless steel **BP 15 SS**